

**STEM WALL FOUNDATION Detail**  
not to scale

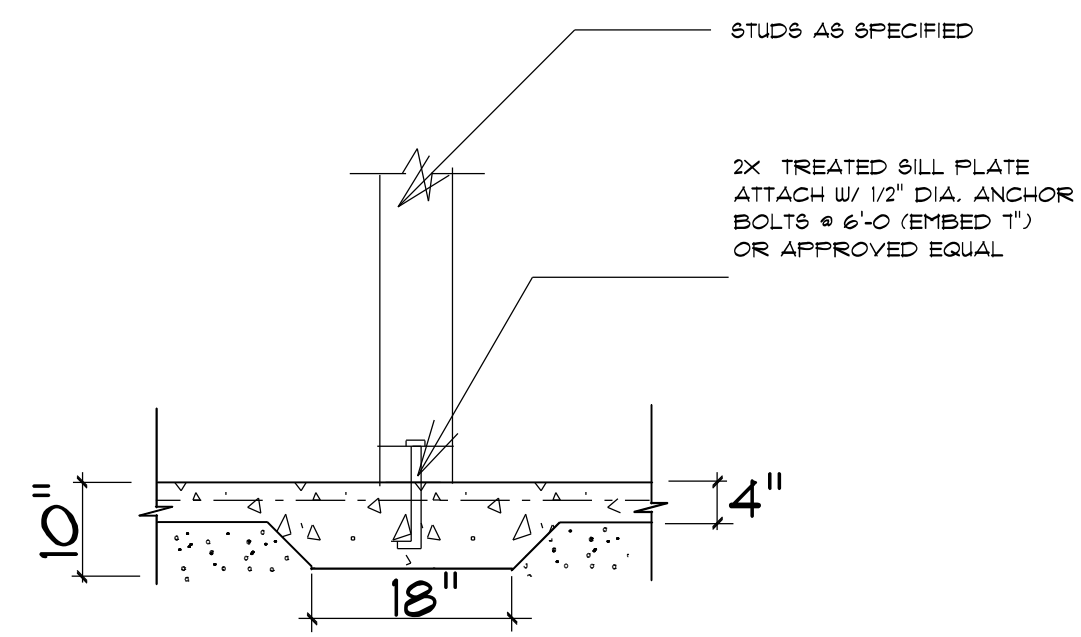

**TYPICAL THICKENED SLAB**  
not to scale

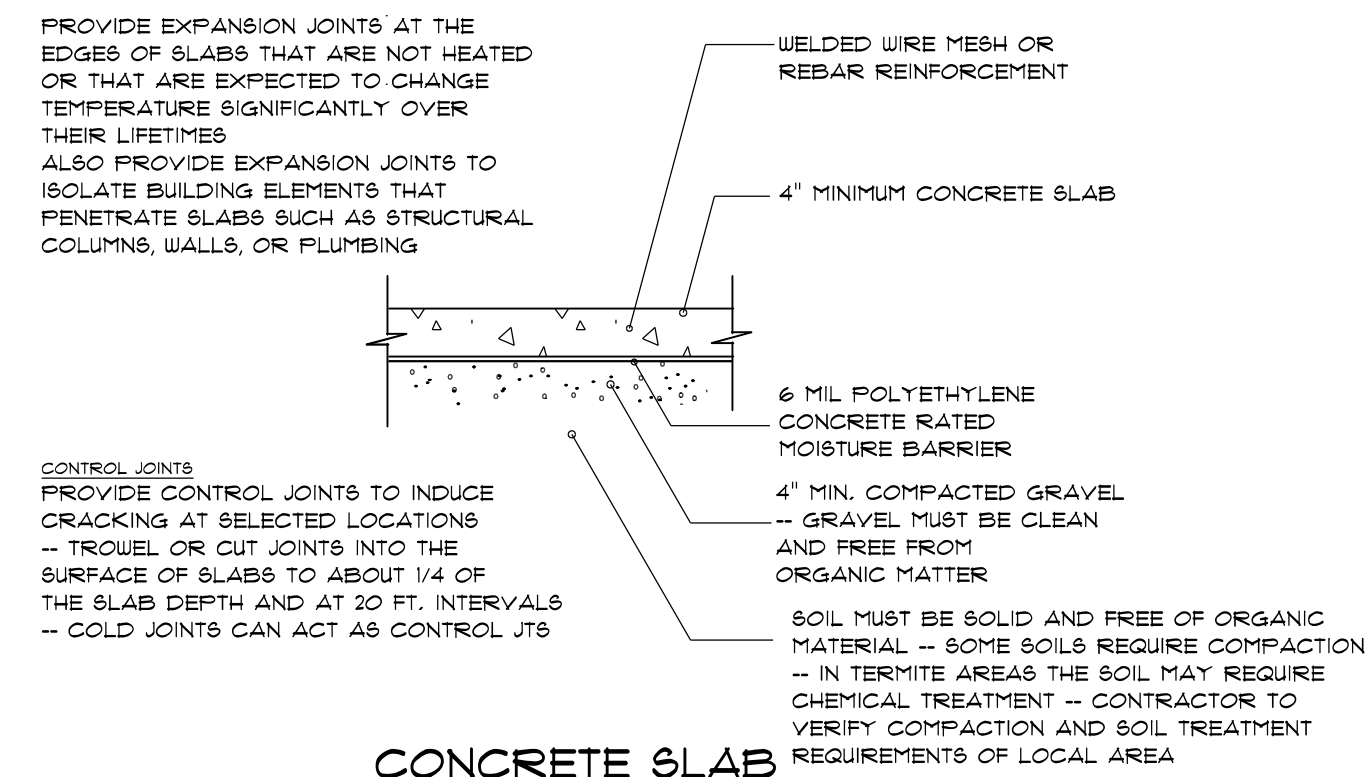

**CONCRETE SLAB DETAILS / NOTES**  
not to scale

**FOUNDATION NOTES:**  
 ALL FOOTINGS SHALL BEAR ON ORIGINAL UNDISTURBED SOIL.  
 THE 28 DAY COMPRESSIVE STRENGTH OF ALL FOOTINGS IS 3000 PSI  
 PROVIDE WATER PROOFING AND PERIMETER DRAINS AS REQUIRED.  
 FOUNDATION CONCRETE MIX TO HAVE 1-1/2" MAX AGGREGATE SIZE. CONCRETE FILL MIX TO HAVE 1/2" MAX AGGREGATE SIZE.  
 FOOTING WIDTHS ARE BASED ON A LOAD-BEARING SOIL CAPACITY OF 2000 PSI.  
 PROVIDE 6 MIL POLY VAPOR BARRIER TO COVER GROUND SURFACE IN CRAWL SPACE  
 ALL ANCHOR BOLTS TO BE 12" LONG, 1/2" DIA. A36 UNO ANCHOR BOLTS SHALL BE SPACE AT A MAX OF 6' OC AND NO MORE THAN 1' FROM EA CORNER.

Termite Soil Treatment: Treat entire slab area soil or crawl space surface before vapor barrier is installed and slab is poured with a state approved termiticide. Termiticide should be applied by a licensed and certified pest control professional by the state of North Carolina.

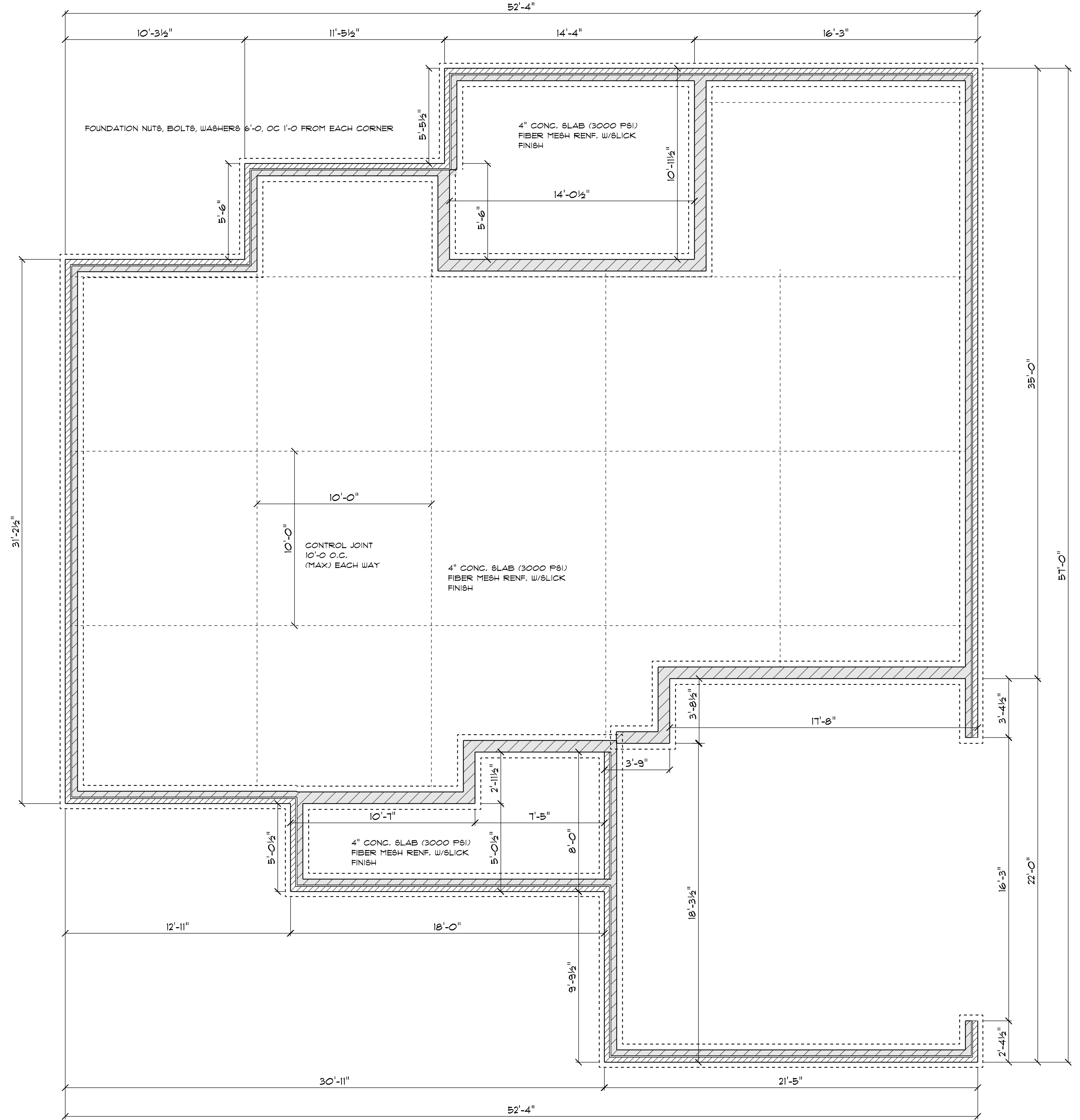

**FOUNDATION PLAN**  
SCALE: 1" = 1/4"